

## Homework #8 Solution Set

(28 points - 1 per problem)

1. *What are two primary advantages of FM over AM?*

The two advantages are noise immunity (FM receivers are relatively unbothered by amplitude disturbances) and fidelity (FM transmitters and receivers can be easily designed for high accuracy reproduction of information signals.)

2. *Define angle modulation.*

Angle modulation is any form of modulation where the phase angle of the carrier signal is varied as it is impressed with intelligence. Both FM and PM cause carrier phase shifts and are therefore both considered to be angle modulation.

3. *Where does modulation usually take place at in an FM transmitter?*

Modulation usually takes place at the oscillator stage in an FM transmitter, since the frequency of the transmitter is being modified in step with the information signal.

4. *Explain the operation of a condenser microphone. How can it be used to generate FM?*

A condenser or capacitor microphone consists of two metal plates, one fixed and the other movable. The two plates form a capacitor whose value varies when the movable plate is caused to vibrate by incoming sound. A condenser microphone can be used to generate FM by connecting it into the tank circuit of an oscillator, where it will cause the oscillator frequency to vary up and down in step with its changing capacitance, which is caused by the incoming sound.

5. *A certain FM transmitter has a resting frequency of 200 KHz, a maximum frequency of 202.5 KHz, and a minimum frequency of 197.5 KHz. An information signal of 3 Vpk, 2.5 KHz is driving the modulator. What is the deviation of the transmitter?*

$$d = f_{\max} - f_c = 202.5 \text{ KHz} - 200 \text{ KHz} = \underline{\underline{2.5 \text{ KHz}}}$$

6. *What is the deviation rate for the transmitter of question 5?*

The deviation rate is equal to the information frequency, so by inspection:

$$DR = f_m = \underline{\underline{2.5 \text{ KHz}}}$$

7. *Recalculate the deviation for the transmitter of question 5 if the information voltage is changed to (a) 1 Vpk ; (b) 6 Vpk*

$$\text{a) } d' = d \left( \frac{V_{m'}}{V_m} \right) = 2.5 \text{ KHz} \left( \frac{1 \text{ Vpk}}{3 \text{ Vpk}} \right) = \underline{\underline{0.833 \text{ KHz}}}$$

$$b) \mathbf{d}' = \mathbf{d} \left( \frac{V_{m'}}{V_m} \right) = 2.5 \text{ KHz} \left( \frac{6V_{pk}}{3V_{pk}} \right) = \underline{\underline{5.0 \text{ KHz}}}$$

8. For each of the following FM signals, calculate the following: Deviation, Percentage of modulation, and Bandwidth by Carson's Rule:

a)  $f_c = 100 \text{ KHz}$ ,  $f_{\max} = 102 \text{ KHz}$ ,  $f_{\min} = 98 \text{ KHz}$ ,  $f_m = 1 \text{ KHz}$ ,  $\mathbf{d}_{\max} = 5 \text{ KHz}$ .

b)  $f_c = 300 \text{ KHz}$ ,  $f_{\max} = 310 \text{ KHz}$ ,  $f_{\min} = 290 \text{ KHz}$ ,  $f_m = 4 \text{ KHz}$ ,  $\mathbf{d}_{\max} = 10 \text{ KHz}$ .

c)  $f_c = 155.450 \text{ MHz}$ ,  $f_{\max} = 155.458 \text{ MHz}$ ,  $f_{\min} = 155.442 \text{ MHz}$ ,  $f_m = 8 \text{ KHz}$ ,  $\mathbf{d}_{\max} = 15 \text{ KHz}$ .

d)  $f_c = 95.7 \text{ MHz}$ ,  $f_{\max} = 95.760 \text{ MHz}$ ,  $f_{\min} = 95.64 \text{ MHz}$ ,  $f_m = 10 \text{ KHz}$ ,  $\mathbf{d}_{\max} = 75 \text{ KHz}$

a)  $\mathbf{d} = f_{\max} - f_c = 102 \text{ KHz} - 100 \text{ KHz} = \underline{\underline{2 \text{ KHz}}}$

$$\% \text{ MOD} = \left( \frac{\mathbf{d}}{\mathbf{d}_{\max}} \right) \times 100\% = \left( \frac{2 \text{ KHz}}{5 \text{ KHz}} \right) \times 100\% = \underline{\underline{40\%}}$$

$$BW \approx 2(f_m + \mathbf{d}) \approx 2(1 \text{ KHz} + 2 \text{ KHz}) \approx \underline{\underline{6 \text{ KHz}}}$$

b)  $\mathbf{d} = f_{\max} - f_c = 310 \text{ KHz} - 300 \text{ KHz} = \underline{\underline{10 \text{ KHz}}}$

$$\% \text{ MOD} = \left( \frac{\mathbf{d}}{\mathbf{d}_{\max}} \right) \times 100\% = \left( \frac{10 \text{ KHz}}{10 \text{ KHz}} \right) \times 100\% = \underline{\underline{100\%}}$$

$$BW \approx 2(f_m + \mathbf{d}) \approx 2(4 \text{ KHz} + 10 \text{ KHz}) \approx \underline{\underline{28 \text{ KHz}}}$$

c)  $\mathbf{d} = f_{\max} - f_c = 155.458 \text{ MHz} - 155.450 \text{ MHz} = \underline{\underline{8 \text{ KHz}}}$

$$\% \text{ MOD} = \left( \frac{\mathbf{d}}{\mathbf{d}_{\max}} \right) \times 100\% = \left( \frac{8 \text{ KHz}}{15 \text{ KHz}} \right) \times 100\% = \underline{\underline{53.3\%}}$$

$$BW \approx 2(f_m + \mathbf{d}) \approx 2(8 \text{ KHz} + 8 \text{ KHz}) \approx \underline{\underline{32 \text{ KHz}}}$$

d)  $\mathbf{d} = f_{\max} - f_c = 95.760 \text{ MHz} - 95.700 \text{ MHz} = \underline{\underline{60 \text{ KHz}}}$

$$\% \text{ MOD} = \left( \frac{\mathbf{d}}{\mathbf{d}_{\max}} \right) \times 100\% = \left( \frac{60 \text{ KHz}}{75 \text{ KHz}} \right) \times 100\% = \underline{\underline{80\%}}$$

$$BW \approx 2(f_m + \mathbf{d}) \approx 2(10 \text{ KHz} + 60 \text{ KHz}) \approx \underline{\underline{140 \text{ KHz}}}$$

9. A certain FM broadcast transmitter produces 25 KHz of deviation when 1 Vpk of information is applied. What information voltage will produce 100% modulation?

Since we know that the deviation in FM is proportional to the amplitude of the information, we can solve this problem by setting up a ratio and solving for the desired unknown:

$$\frac{V_{m'}}{V_m} = \frac{\mathbf{d}'}{\mathbf{d}} \text{ so } V_{m'} = V_m \left( \frac{\mathbf{d}'}{\mathbf{d}} \right) = 1V_{pk} \left( \frac{75 \text{ KHz}}{25 \text{ KHz}} \right) = \underline{\underline{3V_{pk}}}$$

10. Calculate the FM modulation index for each of the FM signals in question 8.

$$\text{a) } m_f = \frac{d}{f_m} = \frac{2\text{KHz}}{1\text{KHz}} = \underline{\underline{2.0\text{rad}}}$$

$$\text{b) } m_f = \frac{d}{f_m} = \frac{10\text{KHz}}{4\text{KHz}} = \underline{\underline{2.5\text{rad}}}$$

$$\text{c) } m_f = \frac{d}{f_m} = \frac{8\text{KHz}}{8\text{KHz}} = \underline{\underline{1.0\text{rad}}}$$

$$\text{d) } m_f = \frac{d}{f_m} = \frac{60\text{KHz}}{10\text{KHz}} = \underline{\underline{6.0\text{rad}}}$$

11. An FM signal is present on a carrier frequency of 100 KHz. The information frequency is 5 KHz, and the deviation is 5 KHz. The unmodulated carrier voltage is 30 V. Using a Bessel table:

a) Calculate the bandwidth of the emission.

b) Draw a spectrogram of the signal, showing all frequencies and voltages.

$$\text{a) } m_f = \frac{d}{f_m} = \frac{5\text{KHz}}{5\text{KHz}} = 1.0\text{rad}$$

The highest Bessel coefficient in the table of figure 8-6 is  $J_3$ , so the bandwidth is:

$$BW = (2)(3)(f_m) = (2)(3)(5\text{ KHz}) = \underline{\underline{30\text{ KHz}}}$$

b) The Bessel coefficients from figure 8-6 are as follows:  $J_0 = 0.765$ ,  $J_1 = 0.440$ ,  $J_2 = 0.115$ , and  $J_3 = 0.020$ . The spectrogram will look as follows:

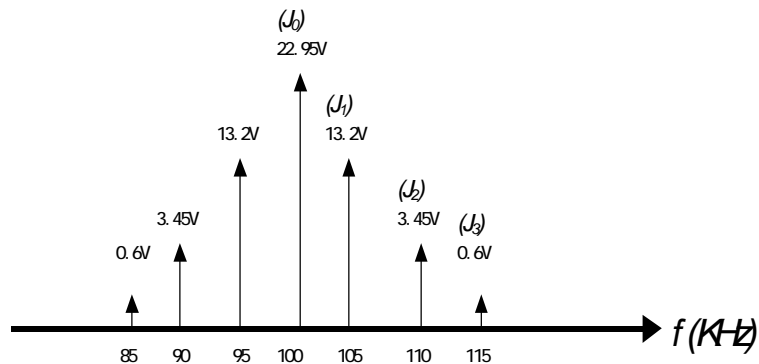

12. For each signal in problem 8:

a) Calculate the bandwidth using a Bessel table.

b) Assuming that  $V_{c(unmod)} = 100\text{ V}$ , draw a spectrogram, showing all frequencies and voltages.

a) Since  $m_f = 2.0\text{ rad}$ , the highest significant sideband pair is  $J_4$  and the BW is:

$$BW = (2)(4)(1\text{KHz}) = \underline{8\text{ KHz}}$$

The Bessel coefficients are:  $J_0 = 0.224$ ,  $J_1 = 0.557$ ,  $J_2 = 0.353$ ,  $J_4 = 0.034$  and the spectrogram looks like this:

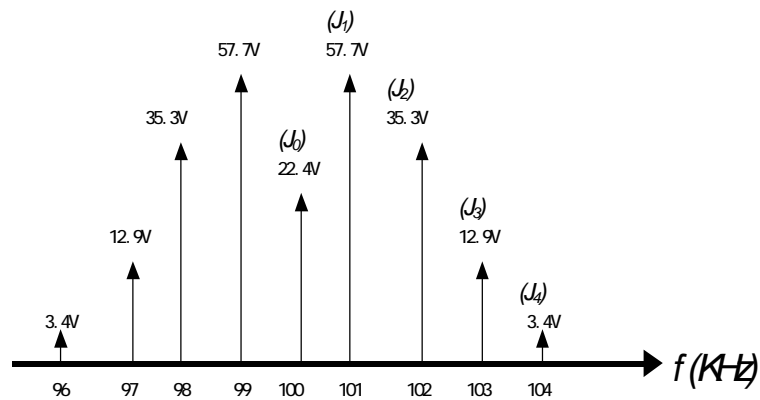

b) Since  $m_f = 2.5\text{ rad}$ , the highest significant sideband pair is  $J_5$  and the BW is:

$$BW = (2)(5)(4\text{KHz}) = \underline{40\text{ KHz}}$$

The Bessel coefficients are:  $J_0 = -0.048$ ,  $J_1 = 0.497$ ,  $J_2 = 0.446$ ,  $J_3 = 0.217$ ,  $J_4 = 0.074$ ,  $J_5 = 0.02$ , and the spectrogram looks like this:

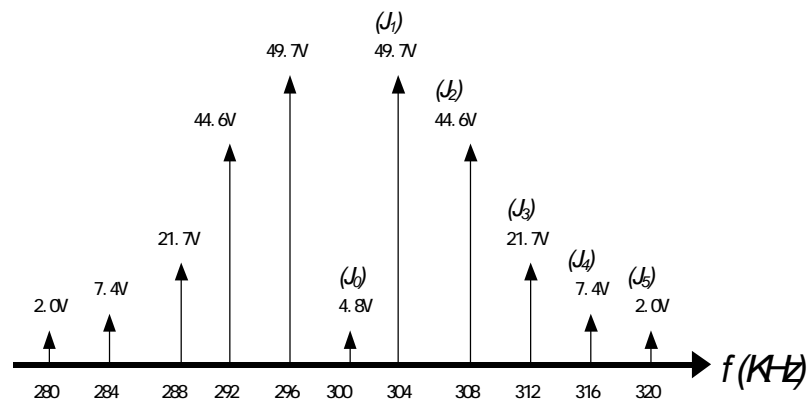

c) Since  $m_f = 1.0$  rad, the highest significant sideband pair is  $J_3$  and the BW is:

$$BW = (2)(3)(8\text{KHz}) = \underline{48\text{ KHz}}$$

The Bessel coefficients are:  $J_0 = 0.765$ ,  $J_1 = 0.440$ ,  $J_2 = 0.115$ ,  $J_3 = 0.02$  and the spectrogram looks like this:

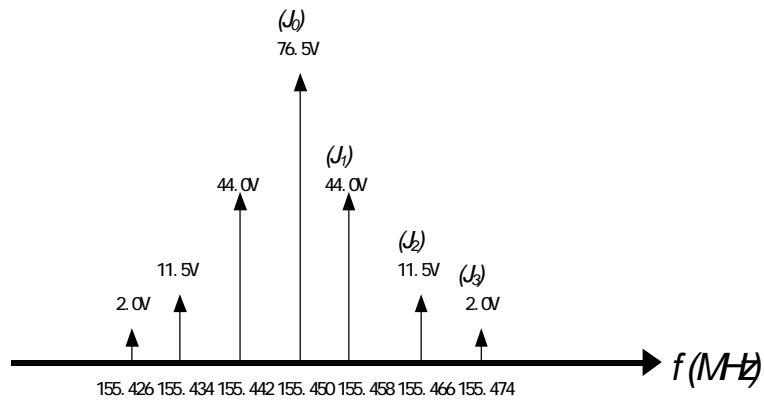

d) Since  $m_f = 6.0$  rad, the highest significant sideband pair is  $J_9$  and the BW is:

$$BW = (2)(9)(10\text{KHz}) = \underline{180\text{ KHz}}$$

The Bessel coefficients are:  $J_0 = 0.151$ ,  $J_1 = -0.277$ ,  $J_2 = -0.243$ ,  $J_3 = 0.115$ ,  $J_4 = 0.358$ ,  $J_5 = 0.362$ ,  $J_6 = 0.246$ ,  $J_7 = 0.130$ ,  $J_8 = 0.057$ ,  $J_9 = 0.021$  and the spectrogram looks like this:

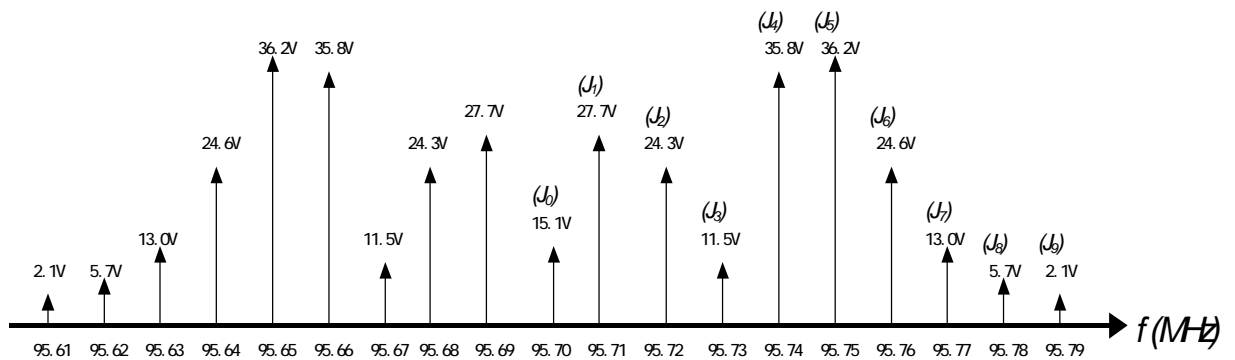

14. How many pairs of sidebands are present in a NBFM signal? How does a NBFM signal appear on a spectrum analyzer?

There is one pair of sidebands in a NBFM signal. On a spectrum analyzer, a NBFM signal looks very much like an AM signal with a very low modulation index.

15. Explain what happens to the amplitude of the carrier frequency component ( $J_0$ ) as the modulation index of an FM signal increases from 0 to 15. At what values of  $m_f$  does the carrier null?

As the modulation index is increased,  $J_0$  decreases, and becomes zero (null) at an index of about 2.4; as the index is increased beyond 2.4,  $J_0$  grows again, this time becoming negative (indicating phase inversion), but never gets beyond a magnitude of about 0.4.  $J_0$  again nulls out at indices of 5.5, 9, and 15, approximately. It gets progressively smaller as the index is increased.

16. Why does the capacitance of a varactor diode vary as the reverse bias is varied?

The capacitance varies because the applied reverse bias changes the physical thickness of the depletion region, which essentially acts as an insulator. This in effect changes the effective "plate spacing" of the internal diode capacitor, changing its capacitance.

17. Using the graph data of figure 8-11, what is the capacitance of an MV-209 varactor diode at a reverse bias of: (a) 10 V ; (b) 11 V ; (c) 12 V

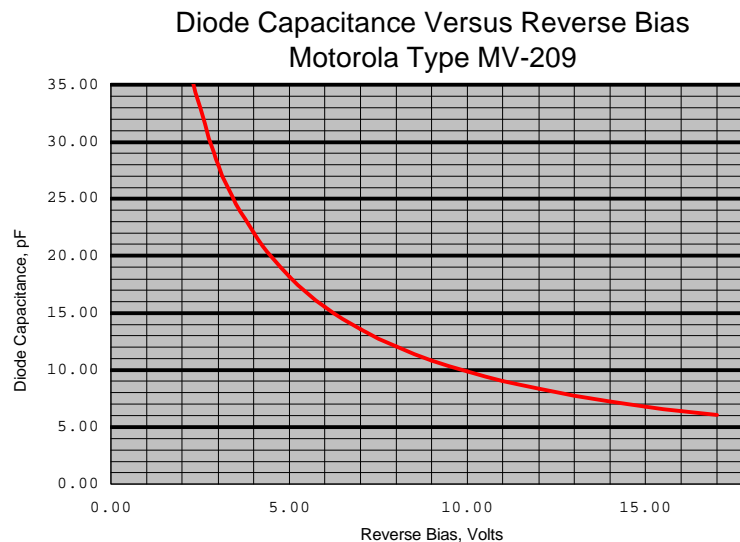

[Figure 8-11]

From inspection of Figure 8-11, the diode capacitances are:

- a) @  $V_r = 10 \text{ V}$ ,  $C_d = \underline{10 \text{ pF}}$
- b) @  $V_r = 11 \text{ V}$ ,  $C_d = \underline{9 \text{ pF}}$
- c) @  $V_r = 12 \text{ V}$ ,  $C_d = \underline{8 \text{ pF}}$

18. An MV-209 varactor diode is coupled in parallel with a 100 mH inductor. What will the frequency of resonance be at (a)  $V=8 \text{ V}$ ; (b)  $V=12 \text{ V}$ ; (c)  $V=15 \text{ V}$ . Round the diode capacitance values to the nearest pF.

- a) @  $V_r = 8 \text{ V}$ ,  $C_d = 12 \text{ pF}$ :

$$f = \frac{1}{2\pi\sqrt{LC_D}} = \frac{1}{2\pi\sqrt{(100\text{mH})(12\text{pF})}} = \underline{\underline{4.594407\text{MHz}}}$$

- b) @  $V_r = 12 \text{ V}$ ,  $C_d = 8 \text{ pF}$ :

$$f = \frac{1}{2\pi\sqrt{LC_D}} = \frac{1}{2\pi\sqrt{(100\text{mH})(8\text{pF})}} = \underline{\underline{5.626977\text{MHz}}}$$

- c) @  $V_r = 15 \text{ V}$ ,  $C_d = 7 \text{ pF}$ :

$$f = \frac{1}{2\pi\sqrt{LC_D}} = \frac{1}{2\pi\sqrt{(100\text{mH})(7\text{pF})}} = \underline{\underline{6.015491\text{MHz}}}$$

19. What is meant by the term drift when referring to radio transmitters?

Drift refers to undesired frequency changes. Drift is considered a long-term effect, occurring over seconds or minutes of time.

20. What problem arises when a quartz crystal oscillator determines an FM transmitter's frequency?

A quartz crystal oscillator is very stable and can not be changed greatly in frequency; very little deviation can be obtained.

21. Draw a block diagram of a Crosby FM transmitter. Using outline form, explain its operation. How does it maintain a stable center frequency while allowing plenty of deviation?

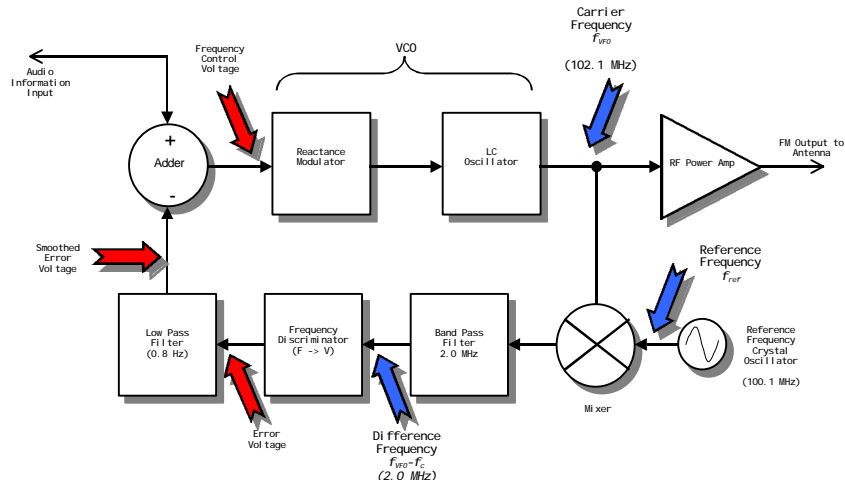

[Figure 8-16]

- A. Reference frequency oscillator controls center frequency of transmitter.
  - 1. Discriminator compares output frequency with reference
  - 2. Discriminator output is low-pass-filtered to reject short-term errors
- B. Modulation signal and error signal are summed before feeding reactance mod.
  - 1. Error signal cancels only long-term error (drift) due to LPF action

22. A 5 MHz carrier with a deviation of 5 KHz is sent through the following frequency multipliers: X3, X5. What is the final carrier frequency and deviation?

The final carrier frequency will be  $(5 \text{ MHz})(X3)(X5) = \underline{75 \text{ MHz}}$ .  
 The final deviation will be  $(5 \text{ KHz})(X3)(X5) = \underline{75 \text{ KHz}}$ .

23. Draw a block diagram of an Armstrong wideband FM exciter, showing typical carrier frequency and deviation at each point.

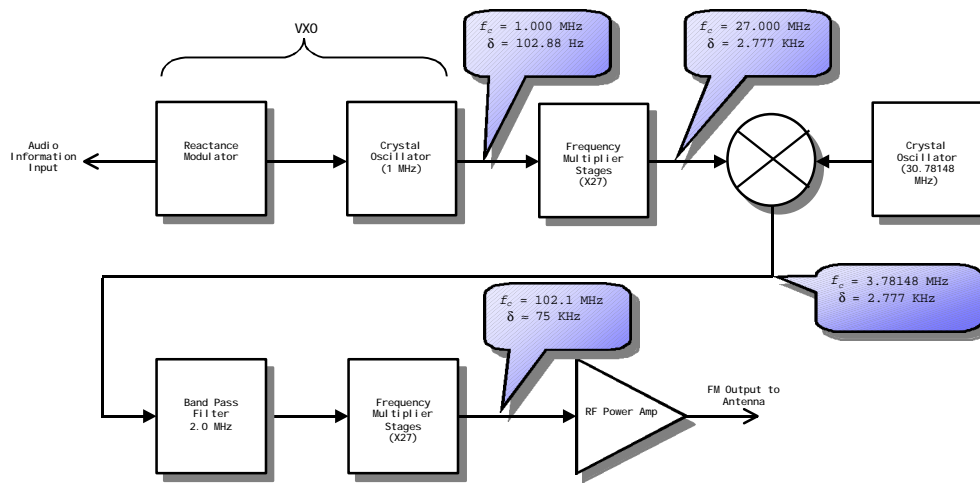

[Figure 8-20]

24. Draw a block diagram of a PLL FM transmitter. What is added to the PLL to allow it to be frequency modulated?



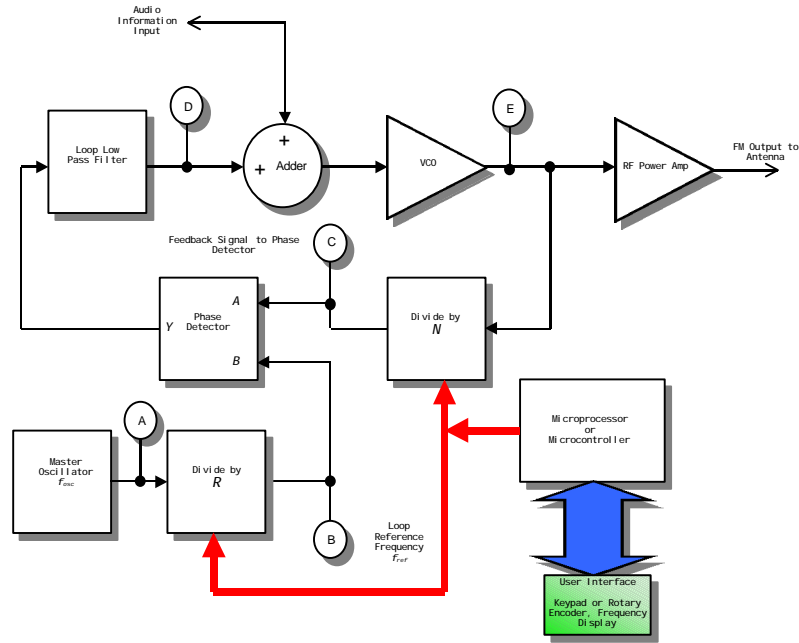

[Figure 8-20]

In order to allow the PLL to be frequency modulated, an adder circuit is inserted into the loop. The adder allows modulating signal to be superimposed upon the VCO control voltage, thus frequency modulating the circuit.

25. If  $f_{osc} = 10.000 \text{ MHz}$ ,  $R = 200$ , and  $N=1978$ , determine the frequencies at test points B, C, and E in the PLL FM transmitter of figure 8-20.

Test point A: Will be  $f_{osc}$  or 10.000 MHz

Test point B: Will be  $f_{osc} / R$  or  $(10.000 \text{ MHz}) / (200)$  or 50 KHz

Test point C: Will be same as test point B, or 50 KHz (Finley's Law)

Test point E: Will be  $N (50 \text{ KHz}) = (1978)(50 \text{ KHz}) = \underline{98.900 \text{ MHz}}$

26. What class of power amplifiers are used in FM transmitters? Why is this an advantage?

Class C power amplifiers are used in FM transmitters. This is an advantage because of the high DC efficiency of class C amplification.

27. What are preemphasis and deemphasis? Why are they necessary?

Preemphasis is the boosting of deviation for high intelligence frequencies at the transmitter, while deemphasis is the attenuation of high intelligence frequencies at the receiver. They are necessary for improving the noise immunity of the FM system, especially at high intelligence frequencies where noise is more bothersome to the listener.

28. Explain the FM capture effect.

The capture effect is seen whenever two signals of different strength (but of the same frequency) are entering an FM receiver. Only the strongest of the signals is demodulated -- it "captures" the receiver. The weaker signal disappears (little or no trace is present).

29. Draw a diagram of the US FM broadcast bandplan. How much space is allocated for each station, including guard bands?

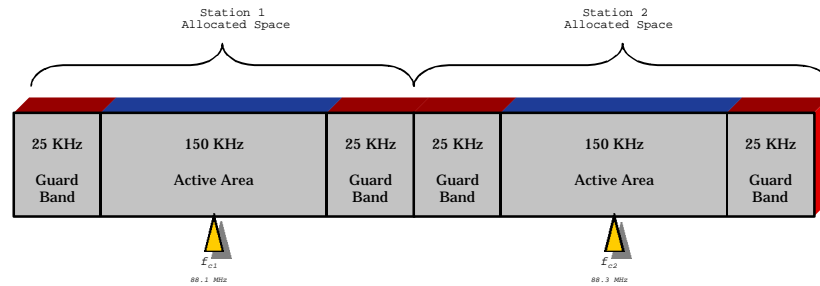

[Figure 8-23]

In the US bandplan, each station receives a 200 KHz "slot," which includes the guard bands.