

Homework #1 Solution Set

14 Points (1 per problem; all work must be shown).

1. Draw a block diagram of a practical radio transmitter. Explain the function of each block.

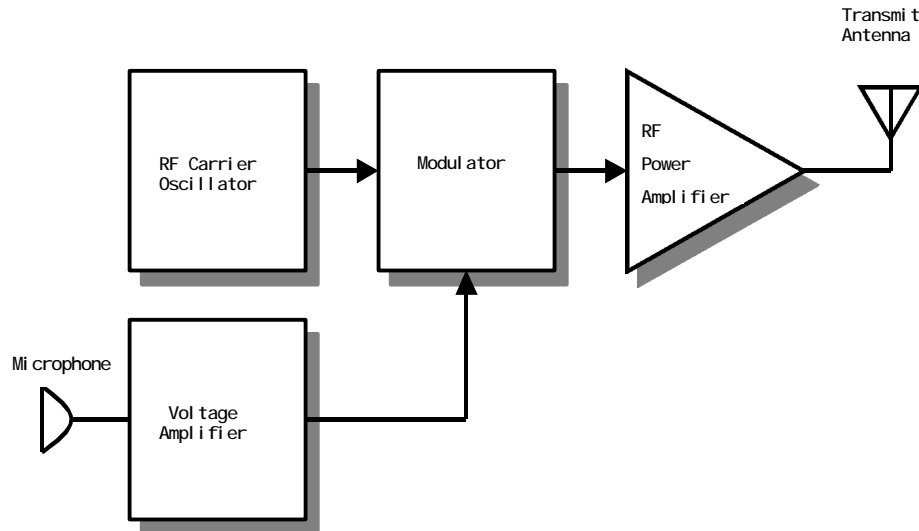

The figure above (which is part of figure 1-5) contains the following parts:

- a) **RF Carrier Oscillator:** Produces the radio frequency AC carrier sine wave.
 - b) **Voltage Amplifier:** Amplifies the weak microphone signal in preparation for modulation.
 - c) **Modulator:** Impresses the amplified intelligence signal onto the carrier signal from the oscillator.
 - d) **RF Power Amplifier:** Provides power gain to the modulated RF carrier signal for driving the antenna (and overcoming path loss.)
 - e) **Antenna:** Converts the electrical energy from the power amplifier into electromagnetic energy (a radio wave.)
2. Draw a block diagram of a radio receiver. Explain what happens in each block.

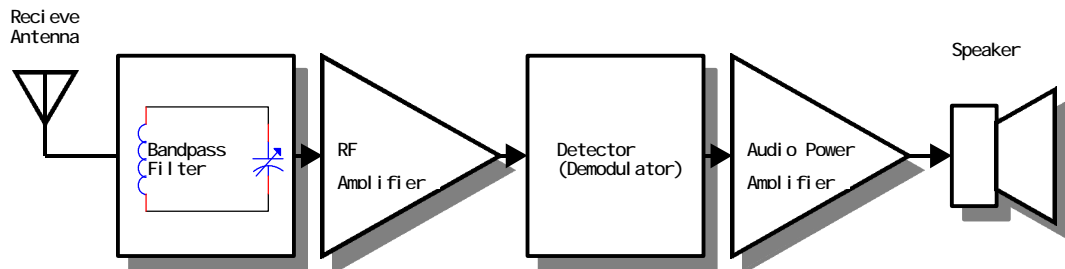

The figure above is a simplified receiver, the same as figure 1-5:

- a) **Receive Antenna:** Converts incoming radio wave energy into electrical energy.
- b) **Bandpass Filter:** Allows desired carrier frequency to pass, rejects all others.
- c) **RF Amplifier:** Amplifies the selected carrier frequency in preparation for

demodulation.

- d) Detector: Recovers a copy of the original information signal from the amplified RF carrier.**
- e) Audio Power Amplifier: Provides both voltage and current gain so that a speaker can be driven.**
- f) Speaker: Converts the recovered information signal back into sound.**

3. *Define modulation. List the three ways a carrier wave can be modulated.*

Modulation is the process of placing information onto a carrier. The three methods are (1) Amplitude Modulation (AM), (2) Frequency Modulation (FM), and (3) Phase Modulation (PM).

4. *What are two reasons why modulation is necessary in radio?*

Modulation is necessary so that (1) Antenna lengths can be reasonable (short), and (2) Stations can be separated from each other [frequency-division multiplexing].

5. *List all the transducers shown in figure 1-5. For each transducer, give the type of input and output energy.*

- a) The microphone converts sound into electrical energy.**
- b) The antennas convert electrical RF energy into radio waves, and vice versa.**
- c) The loudspeaker converts electrical energy back into sound.**

6. *What is the purpose of the oscillator in a radio transmitter?*

The purpose of the oscillator is to generate the radio frequency (RF) carrier signal. The frequency of the oscillator determines where on the dial the station will be received.

7. *Define wavelength. How do changes in frequency affect wavelength?*

Wavelength is the the distance that a radio wave travels in one cycle. As frequency is increased, wavelength decreases; as frequency decreases, wavelength increases.

8. *Calculate the wavelength of the following radio signals:*

- a) 1 MHz b) 10 MHz c) 2.8 MHz d) 54 MHz

$$\text{a) } \lambda = \frac{v}{f} = \frac{3 \times 10^8 \text{ m/s}}{1 \text{ MHz}} = \underline{\underline{300 \text{ m}}}$$

$$\text{b) } \lambda = \frac{v}{f} = \frac{3 \times 10^8 \text{ m/s}}{10 \text{ MHz}} = \underline{\underline{30 \text{ m}}}$$

$$\text{c) } \lambda = \frac{v}{f} = \frac{3 \times 10^8 \text{ m/s}}{2.8 \text{ MHz}} = \underline{\underline{107.14 \text{ m}}}$$

$$\text{d) } \lambda = \frac{v}{f} = \frac{3 \times 10^8 \text{ m/s}}{54 \text{ MHz}} = \underline{\underline{5.55 \text{ m}}}$$

9. How long is one-quarter wavelength at each of the frequencies of question 8?

$$\text{a) } \frac{l}{4} = \frac{300m}{4} = \underline{\underline{75m}}$$

$$\text{b) } \frac{l}{4} = \frac{30m}{4} = \underline{\underline{7.5m}}$$

$$\text{c) } \frac{l}{4} = \frac{107.14m}{4} = \underline{\underline{26.79m}}$$

$$\text{d) } \frac{l}{4} = \frac{5.5m}{4} = \underline{\underline{1.38m}}$$

10. Calculate the frequency that corresponds to each of the following wavelengths:

a) 10 m b) 2 m c) 15 m d) 70 cm

By solving the wavelength formula for frequency, we get the following:

$$\text{a) } f = \frac{v}{l} = \frac{3 \times 10^8 \text{ m/s}}{10m} = \underline{\underline{30MHz}}$$

$$\text{b) } f = \frac{v}{l} = \frac{3 \times 10^8 \text{ m/s}}{2m} = \underline{\underline{150MHz}}$$

$$\text{c) } f = \frac{v}{l} = \frac{3 \times 10^8 \text{ m/s}}{15m} = \underline{\underline{20MHz}}$$

$$\text{d) } f = \frac{v}{l} = \frac{3 \times 10^8 \text{ m/s}}{70cm} = \underline{\underline{428.57MHz}}$$

11. What is the approximate operating frequency of each antenna listed below? The fraction of a wavelength is given for each unit.

a) Length = 56", 1/4 λ

$$L_{\text{meters}} = 56" \times \left(\frac{1m}{39.37"} \right) = 1.422m = (l / 4)$$

$$l = 4(l / 4) = 4(1.422m) = 5.69m$$

$$f = \frac{v}{l} = \frac{3 \times 10^8 \text{ m/s}}{5.69m} = \underline{\underline{52.72MHz}}$$

b) Length = 56", 1/2 λ

$$L_{\text{meters}} = 56" \times \left(\frac{1m}{39.37"} \right) = 1.422m = (l / 2)$$

$$l = 2(l / 2) = 2(1.422m) = 2.84m$$

$$f = \frac{v}{\lambda} = \frac{3 \times 10^8 \text{ m/s}}{2.84 \text{ m}} = \underline{\underline{105.46 \text{ MHz}}}$$

c) Length = 0.5m, 1/4 λ

$$\lambda = 4(L) = 4(0.5 \text{ m}) = 2 \text{ m}$$

$$f = \frac{v}{\lambda} = \frac{3 \times 10^8 \text{ m/s}}{2 \text{ m}} = \underline{\underline{150 \text{ MHz}}}$$

d) Length = 10m, 1/2 λ

$$\lambda = 2(L) = 2(10 \text{ m}) = 20 \text{ m}$$

$$f = \frac{v}{\lambda} = \frac{3 \times 10^8 \text{ m/s}}{20 \text{ m}} = \underline{\underline{15 \text{ MHz}}}$$

12. List the three steps of troubleshooting a system, in order.

- 1. Visual (and other) Inspection**
- 2. Check power supplies.**
- 3. Check inputs and outputs.**

13. Why are power supplies the most failure-prone portion of electronic systems?

The power supply tends to be the most heavily stressed portion of electronic systems. It supplies the total power, and while it is doing this, is exposed to all sorts of electrical transients from the AC/DC power inputs.

14. A unit just like the one of figure 1-7 has come in for servicing. The complaint on the repair order states "won't transmit." When connected to a dummy load and RF power meter, the set shows no power output when the microphone is keyed.

a) What will be the first step taken when this unit is troubleshot?

b) List the power supply voltage test points (by voltage) that will be measured in the second step of troubleshooting.

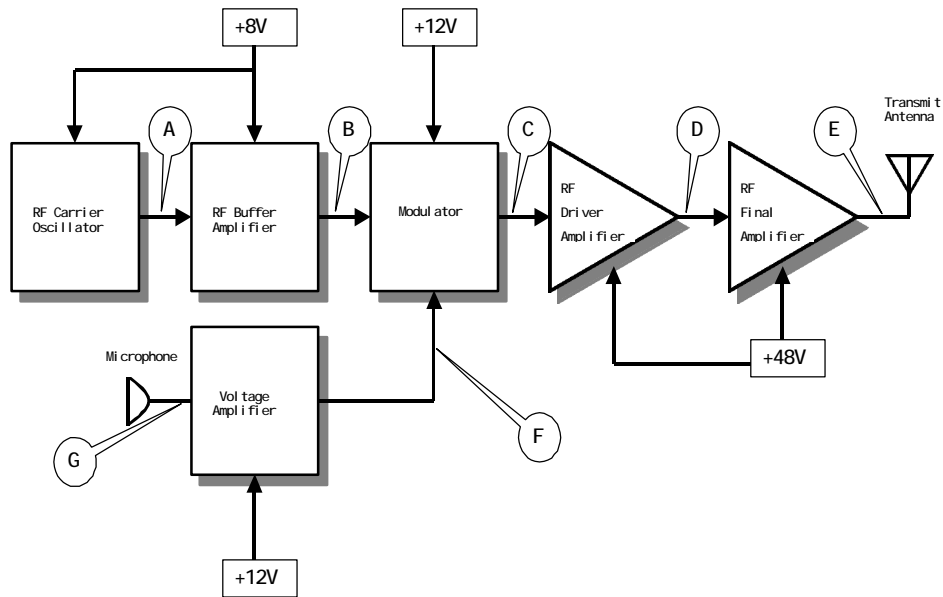

a) The first step should be a **visual inspection** of the unit, which would include checking the settings on all controls.

b) There are *three* important power supply test points: **48V** at the final PA, **12V** at the modulator stage / mic amplifier, and **8V** at the oscillator.

15. The power supply test points in the set of question 14 measured good. The following oscilloscope measurements were made with the microphone keyed:

* Test point E, 0 Vpp RF ; * Test point C, 10 Vpp RF

* Test point B, 5 Vpp RF ; * Test point D, 0 Vpp RF

* Test point F, 1 Vpp AF (Intelligence)

What stage or stages is most likely causing the problem?

The driver amplifier is the most likely source of the problem. It has a signal of 10 Vpp RF coming into it (Test point C), but it is producing no output (0 Vpp RF at test point D).